



We're There.

PN2 NACE Gauge - MR0175-2002



- **Designed for sour gas applications requiring NACE Standards MR0175-2002 (MR0103-2003 available)**
- **Gauge meets minimum hardness requirements**
- **Pressure release disk standard**
- **CRN registered**
- **5 year warranty**

Specifications	
Dial	4" (100mm) aluminum with black and red markings
Case	304 SS
Lens	Laminated safety glass
Ring	304 SS, bayonet
Socket	316L SS
Connection	1/4" or 1/2" NPT, bottom or back
Bourdon Tube	316 SS
Movement	SS
Pointer	Aluminum, anodized black, micrometer adjustable
Fill Liquid	Glycerin/H ₂ O
Ambient/Process Temperature	-40°F to 150°F (-40°C to 65°C) filled
Accuracy	±1% ANSI/ASME Grade A
Enclosure Rating	IP65

Order Codes

Dial Size	4" (100mm)			
	1/4" Bottom	1/4" Back	1/2" Bottom	1/2" Back
30" Hg. vacuum/kPa	PN2640N	PN21090N	PN2655N	-
30"/0/15 psi/kPa	PN21036N	-	PN21044N	-
30"/0/30 psi/kPa	PN21037N	-	PN21045N	-
30"/0/60 psi/kPa	PN21038N	-	PN21046N	-
30"/0/100 psi/kPa	PN21039N	-	PN21047N	-
30"/0/160 psi/kPa	PN21040N	-	PN21048N	-
30"/0/200 psi/kPa	PN21042N	-	PN21050N	-
30"/0/300 psi/kPa	PN21043N	-	PN21051N	-
0 - 15 psi/kPa	PN2641N	PN21091N	PN2656N	-
0 - 30 psi/kPa	PN2642N	PN21092N	PN2657N	-
0 - 60 psi/kPa	PN2643N	PN21093N	PN2658N	-
0 - 100 psi/kPa	PN2644N	PN21094N	PN2659N	-
0 - 160 psi/kPa	PN2645N	PN21095N	PN2660N	-
0 - 200 psi/kPa	PN2646N	PN21096N	PN2661N	-
0 - 300 psi/kPa	PN2647N	PN21097N	PN2662N	-
0 - 400 psi/kPa	PN2650N	-	PN2666N	-
0 - 600 psi/kPa	PN2648N	PN21098N	PN2663N	-
0 - 1,000 psi/kPa	PN2649N	PN21099N	PN2664N	-
0 - 1,500 psi/kPa	-	-	PN2665N	PN21190N
0 - 2,000 psi/kPa	-	-	PN2667N	PN21191N
0 - 3,000 psi/kPa	-	-	PN2668N	PN21192N
0 - 5,000 psi/kPa	-	-	PN2669N	PN21193N
0 - 10,000 psi/kPa	-	-	PN2670N	PN21194N
0 - 15,000 psi/kPa	-	-	PN2671N	PN21195N
0 - 20,000 psi/kPa	-	-	PN2672N	PN21196N

Option suffix for above order codes only:

4DRY = Supply above gauge less liquid fill
4UC-P = 4" (100mm) U-Clamp

4FF = 4" (100mm) Front Flange
4BF = 4" (100mm) Back Flange

4" (100mm) Bottom Connection

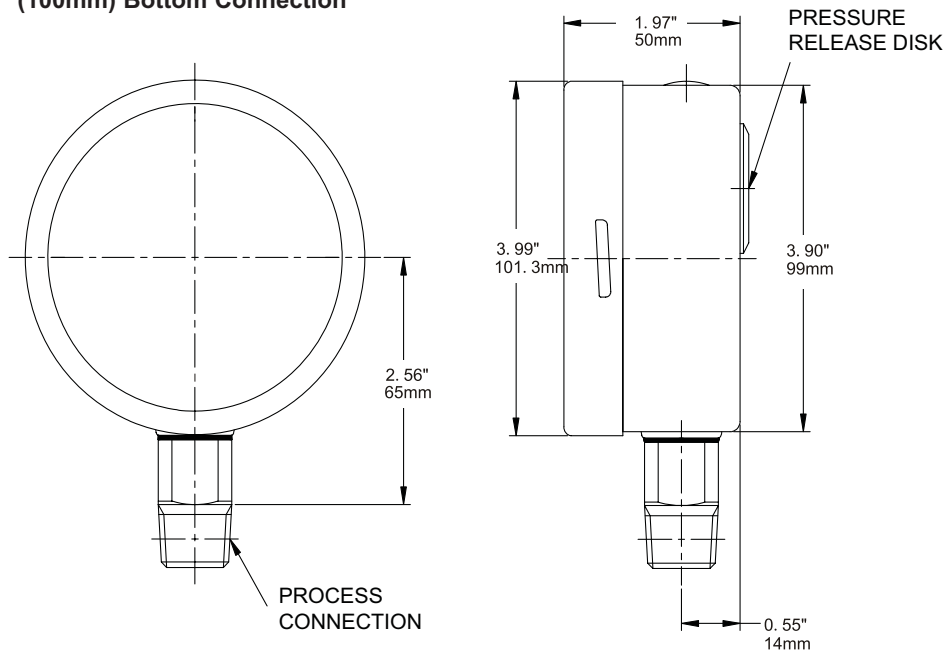

Winters Instruments operates globally and is distributed in over 80 countries. Please contact us for more information or to find a distributor near you.

Corporate

Winters Instruments
121 Railside Road
Toronto, Ontario
M3A 1B2
Tel: 416-444-2345
Fax: 416-444-8979
1-800-WINTERS
sales@winters.com

Canada - Calgary

Winters Instruments
8 - 2807 107th Ave. SE
Calgary, Alberta
T2Z 4M2
Tel: 403-723-6645
Fax: 403-723-6647
1-800-WINTERS
calgary@winters.com

USA - Buffalo

Winters Instruments
600 Ensminger Road
Buffalo, New York
14150
Tel: 716-874-8700
Fax: 716-874-8800
1-800-WINTERS
usasales@winters.com

USA - Houston

Winters Instruments
11050 West Little York Road
Building B-7
Houston, Texas
77041
Tel: 713-983-8607
Fax: 713-983-8608
usasales@winters.com

Latin America

Winters Instruments
Albarellos 1916 1° Piso
E3, E4, E5
B1640BIN, Martinez
Buenos Aires, Argentina
Tel: 54-11-4733-3003
Fax: 54-11-4733-0572
latinsales@winters.com
www.winters.com.ar

Asia

Winters Instruments
Suite 103-109, Shanghai
WitHub Hi-Tech Business Center
No. 333 Hongqiao Road
Shanghai 200030 China
Tel: 86-21-6104-2610
Fax: 86-21-6104-2615
asiasales@winters.com

Distributed by: